

ROI Cabmate®
Cab Suspension

LINK®

Link Mfg. Ltd.
223 15th St. N.E.
Sioux Center, IA USA
51250-2120
www.linkmfg.com

**QUESTIONS?
CALL CUSTOMER
SERVICE
1-800-222-6283**

INSTALLATION INSTRUCTIONS

Cab Suspension

PACCAR

PETERBILT 567 / 579

KENWORTH T680 / OT880 / W990

SLEEPER CABS

MODEL YEAR 2017 & NEWER

LINK PART NO.
26302030



IMPORTANT: IT IS IMPORTANT THAT THE ENTIRE INSTALLATION INSTRUCTIONS BE READ THOROUGHLY BEFORE PROCEEDING WITH SUSPENSION INSTALLATION.





1. INTRODUCTION

Thank you for choosing a Link ROI Cabmate Suspension. We want to help you get the best results from this suspension and to operate it safely. This manual contains information to introduce you to the Link ROI Cabmate Suspension and to assist you with its installation. This manual is intended solely for use with this product.

All information in this manual is based on the latest information available at the time of printing. Link Manufacturing reserves the right to change its products or manuals at any time without notice.

Damaged components should be returned to Link with a pre-arranged Returned Materials Authorization (RMA) number through the Customer Service Department. The damaged component may then be replaced if in compliance with warranty conditions.

2. SAFETY SYMBOLS, TORQUE SYMBOL, and NOTES

	DANGER indicates a hazardous situation which if not avoided, will result in death or serious injury.
	WARNING indicates a potentially hazardous situation which, if not avoided, could result in death or serious injury.
	CAUTION indicates a potentially hazardous situation which, if not avoided, could result in minor or moderate injury.
	NOTICE indicates a potentially hazardous situation which, if not avoided, may result in property damage.
	TORQUE indicates named fasteners are to be tightened to a specified torque value.
NOTE:	A Note provides information or suggestions that help you correctly perform a task.

3. SAFE WORKING PRACTICES:

3.1 CAUTION

When handling parts, wear appropriate gloves, eyeglasses, ear protection, and other safety equipment.

3.2 CAUTION

Practice safe lifting procedures. Consider size, shape, and weight of assemblies. Obtain help or the assistance of a crane when lifting heavy assemblies. Make certain the path of travel is clear.

4. INSTALLATION GUIDELINES

4.1

In order for this Cabmate suspension to operate properly, it must operate in the parameters specified by Link.

4.2

No alterations of any Link Cabmate suspension component is permitted without proper authorization from qualified Link personnel.

4.3

No welding of any suspension components is permitted except when specified by Link.

4.4 CAUTION

The vehicle manufacturer should be consulted before any modifications are made to the frame of the vehicle. Cutting or altering the frame in certain areas may affect the manufacturer's warranty.

4.5 CAUTION

Proper tightening of fasteners is important to the performance and safety of the suspension. Follow all torque specifications throughout the instructions. Refer to manufacturer's torque specifications when reinstalling any original fasteners.

4.6 NOTICE

Link Manufacturing is not responsible for optional configurations or third-party equipment that restrict the installation of the ROI Cabmate.

5. PREP VEHICLE FOR ROI CABMATE INSTALLATION (PRE-INSTALL STEPS)

WARNING

To prevent injury from compressed air and unintended cab motion, do not connect the cab suspension to the air source until the cab suspension is completely assembled and you have read and understood the owner's manual.

Tools Required

- Pliers
- Airline cutting tool
- Metric socket set
- Metric wrench set
- Standard socket set
- Standard wrench set
- Torque wrench
- Hex key: 3mm

5.1

Measure the air spring height between the air spring mounting surfaces. Verify this dimension is approximately 5.25". Do not proceed with the installation if the dimension is off by more than 0.5". Record the actual measurement. When the installation is complete, the distance will be measured again to verify the air spring height has not changed (FIG.1).

5.2

Jack up the cab between the driver's side frame rail and rear of cab.

5.3

Disconnect airlines from the air springs and the height control valve.

5.4

Verify the cab is fully supported.

5.5

Verify the vehicle is off and remove the key to prevent others from starting the vehicle.

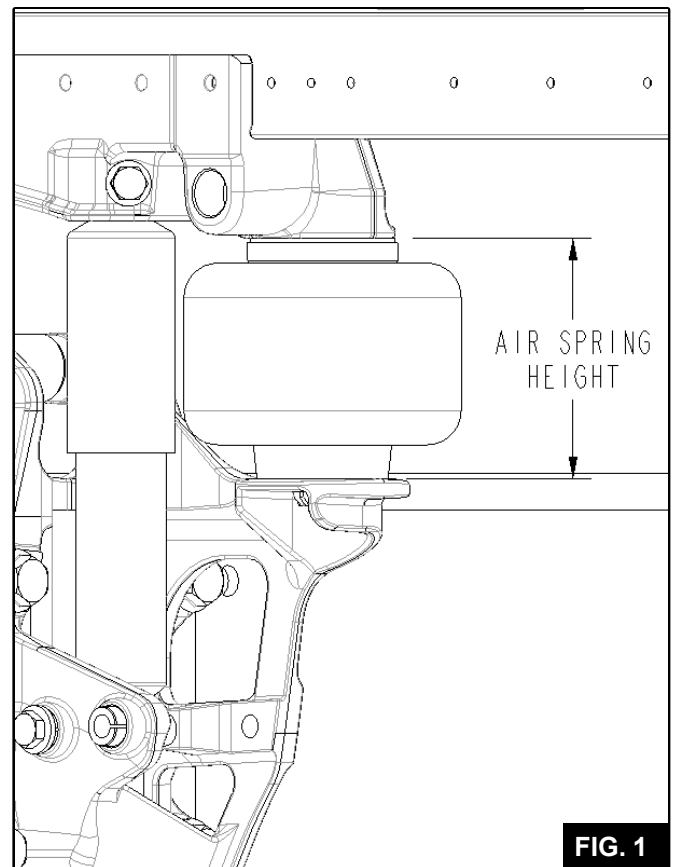

6. MOUNT THE CONTROL BOX

WARNING

Failure to have rear of the cab fully supported will cause motion of the rear of the cab, which may result in operator injury. See section 5 for instructions on supporting the rear of the cab.

6.1

Locate the holes under the cab sill on the passenger side of the truck (**FIG.2**).

NOTE: It may be necessary to remove the (4) nuts securing the crossmember to the frame mounts to remove the crossmember assembly. (Two nuts on each side) (**FIG.4**)

6.2

Loosely connect the front and rear brackets to the cab frame with the (4) 1/4 x 3/4 bolts and (2) 1/4 hex nuts provided (**FIG.3**).

6.3

Place the control box between the two brackets. Secure the box to the brackets with the (3) 1/4 x 5/8 flange head bolts provided (**FIG.4**).

 **TORQUE** 1/4" fasteners to 4-5 FT-LBS

6.4

Tighten the four bolts from step 6.2. The control box is now secured.

 **TORQUE** 1/4" fasteners to 4-5 FT-LBS

6.5

Mount the height control sensor assembly to the control box using the (2) 1/4 x 5/8 flange head bolts provided (**FIG.5**).

 **TORQUE** 1/4" fasteners to 4-5 FT-LBS

6.6

Place the pivot ball mount clamp on the top flange of the frame rail below the height control sensor. Do not tighten the bolts (**FIG.5**).

6.7

Connect the height control linkage between the pivot ball and the height control sensor (**FIG.5**).

6.8

Position the linkage mount such that the linkage is vertical when viewed from the lateral and longitudinal directions. Tighten the two bolts that have been pre-assembled to the mount to secure the position (**FIG.5 & FIG.7**).

 **TORQUE** 1/4" fasteners to 4-5 FT-LBS

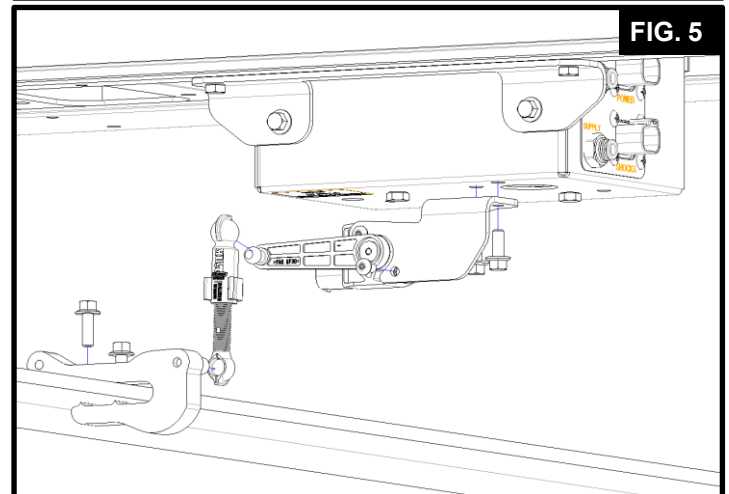
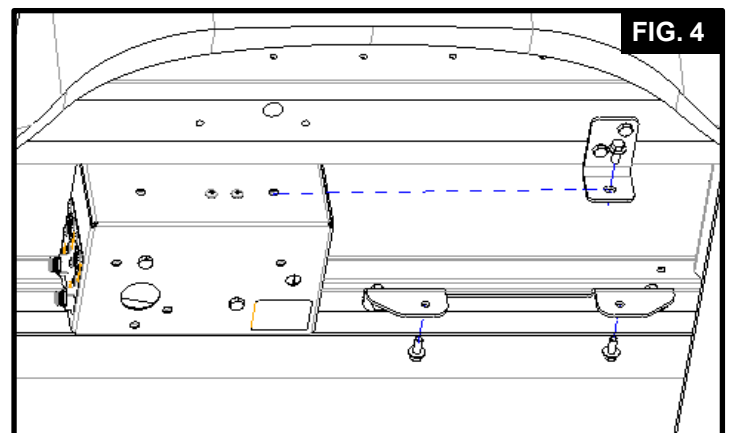
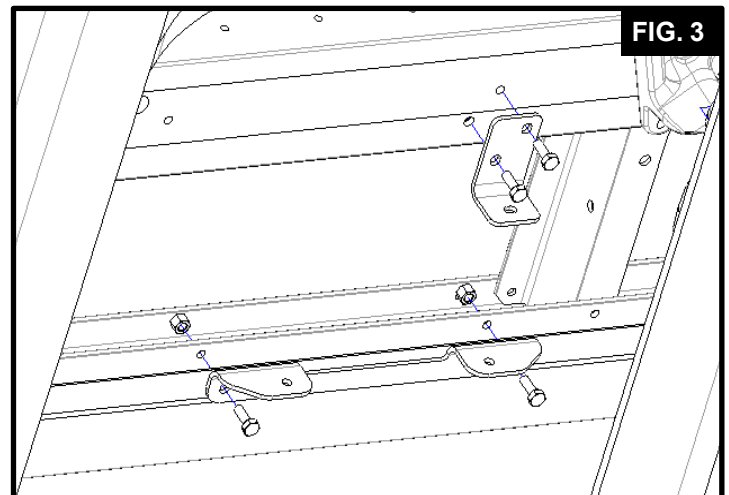
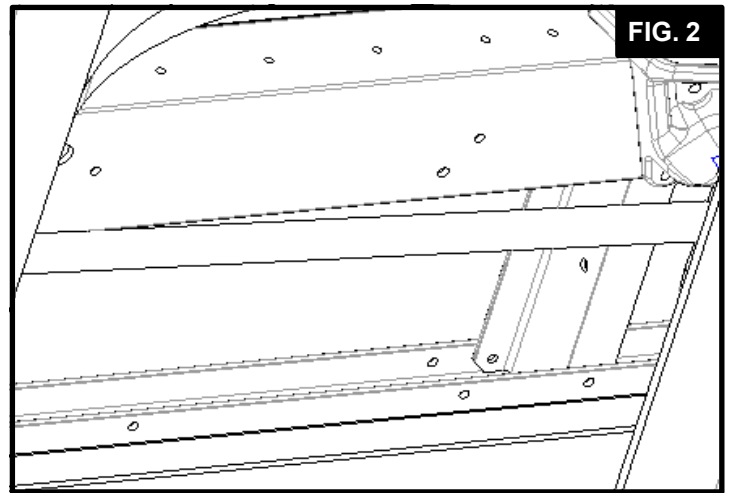

6. MOUNT THE CONTROL BOX (ALTERNATIVE MOUNTING)

6.9

Locate the holes under the cab sill on the driver side of the truck.

6.10

Follow steps 6.2 - 6.4 for mounting the box to the cab of the truck.

6.11

Identify the driver side height control sensor bracket (**FIG.6**).

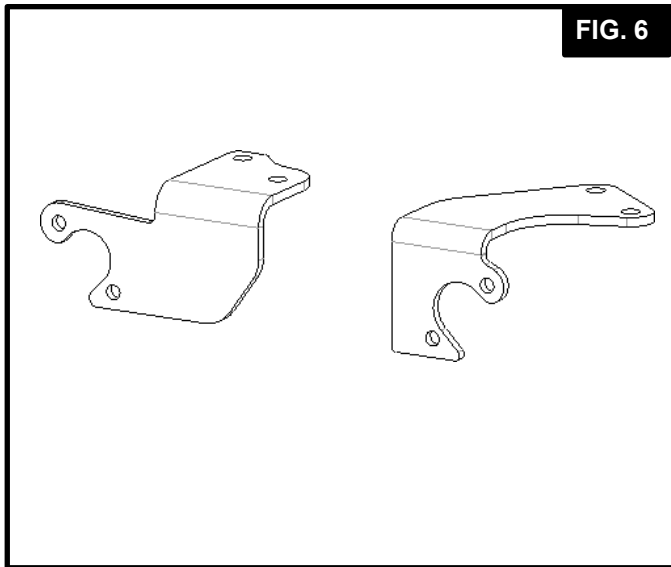

6.12

Follow steps 6.5 - 6.8 for installing the height control sensor, linkage, and pivot ball mount clamp (**FIG. 5 & FIG. 7**).

NOTE: The installation steps are the same only in a mirrored orientation.

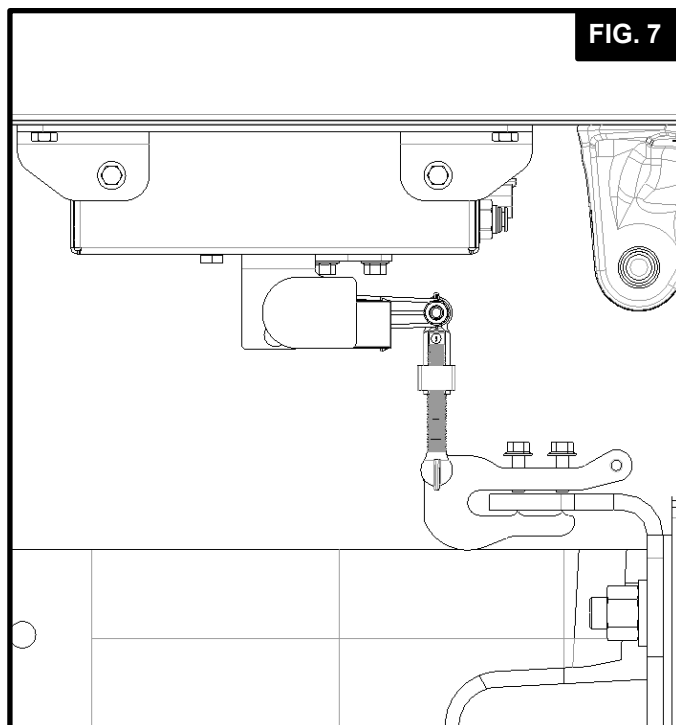

7. REPLACING SHOCKS

7.1

Starting on the passenger side of the truck, remove the bolt, nut and washers from the lower shock mount. Retain these parts as they will be reused (**FIG.8**).

7.2

Remove the bolt from the top shock mount. Retain the bolt as it will be reused (**FIG.8**).

7.3

Remove the shock. The upper shock joint contains a machined hole for a press fit split bushing. Ensure the shock sleeve is free of this hole before attempting to remove the shock. The shock will not be reused and may be discarded (**FIG.8**).

7.4

Repeat steps 7.1-7.3 on the driver side of the truck.

7.5

Using the (2) black straps provided, slip one around the length of each new ROI shock (**FIG.9**).

⚠ WARNING The straps are required to meet or exceed the tensile requirements of the stock suspension. The straps do not contribute or interfere with the functionality of the ROI Cabmate.

7.6

Starting on the passenger side of the truck, place the ROI shock into the cab and frame mounts (**FIG. 9**).

NOTICE The ROI shock is gas-charged and may require the cab to be raised slightly to allow the free length of the shock to align with the mounting holes.

7.7

Complete the upper shock connection using the bolt removed in step 7.2 (**FIG.9**).

NOTE: Refer to manufacturer's torque specifications

7.8

Using the spacers provided, place one on each side of the lower shock sleeve. Complete the lower shock connection using the bolt, nut and washers removed in step 7.1 (**FIG.9**).

NOTE: Refer to manufacturer's torque specifications.

NOTE: The spacers can be glued to the side of the shock bushing for easier installation.

7.9

Repeat steps 7.6-7.8 on the driver side of the truck.

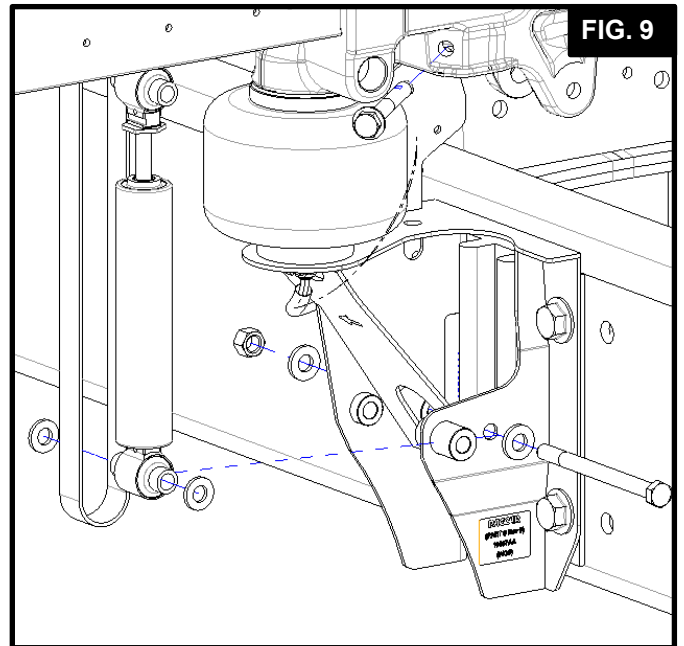
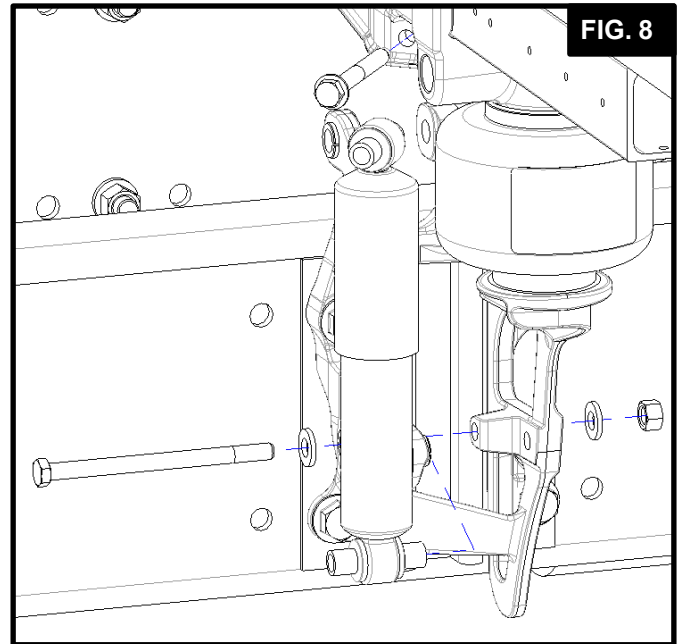

8. INSTALL NEW CAB SUSPENSION ELECTRICAL AND AIRLINE COMPONENTS

8.1

Use the provided airline and airline fittings to connect the vehicle air supply and air spring to the control box (**FIG. 10**).

⚠ WARNING

Connecting airlines to the vehicle supply and connecting to vehicle power may cause the cab air springs to inflate, resulting in cab movement. To prevent injury, ensure cab is blocked up and no operators are in the path of cab motion.

8.2

Connect the shock extension harness into the 'SHOCKS' plug on the control box. Route one end of the harness to each shock absorber and connect. Ensure there is appropriate slack in the harness to account for the vertical suspension travel. Loop excess harness length and secure (**FIG. 11**).

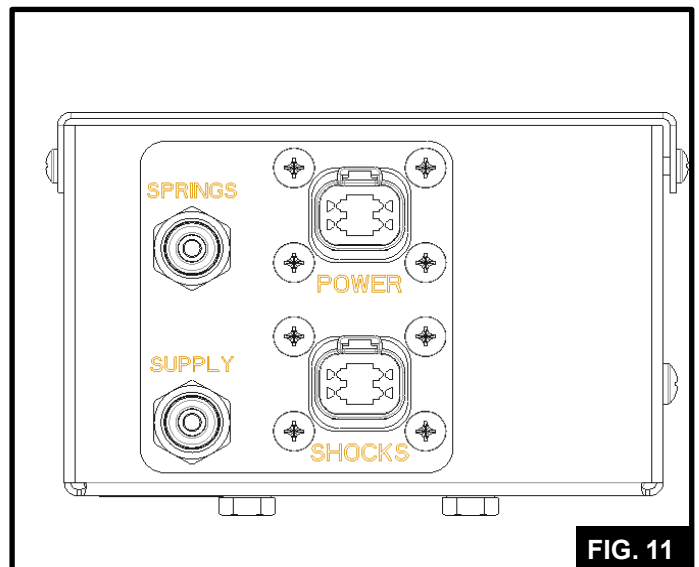
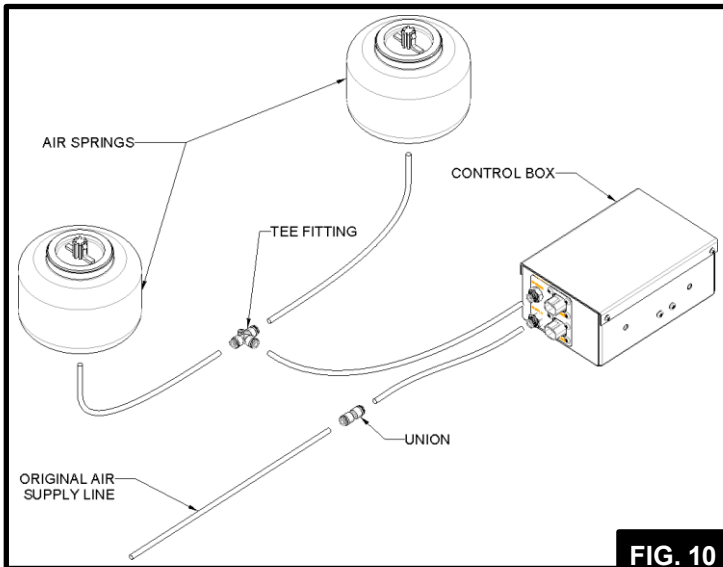

8.3

Run the main power harness from the 'POWER' connector of the control box (**FIG. 11**) into the cab. Route the harness through the dash and to the tie-in location. Loop and strap any excess harness. Strip the wires at the ends of the extension harness.

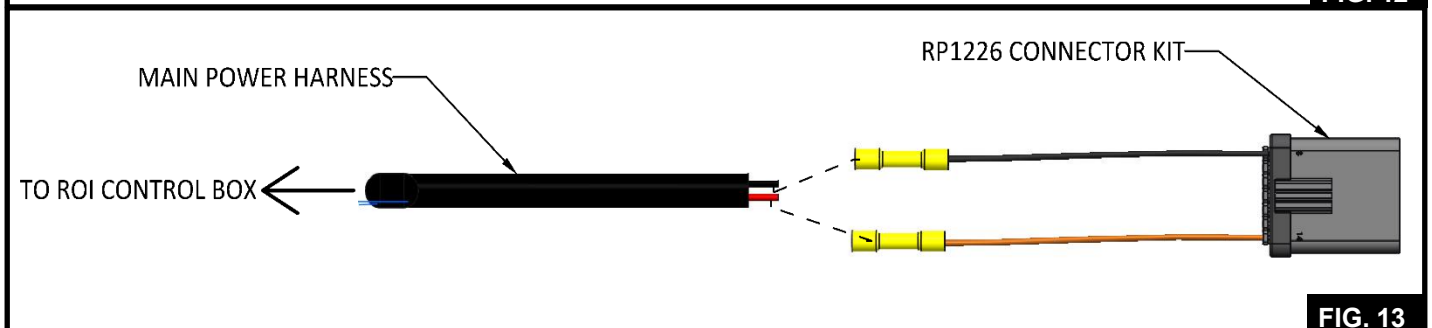
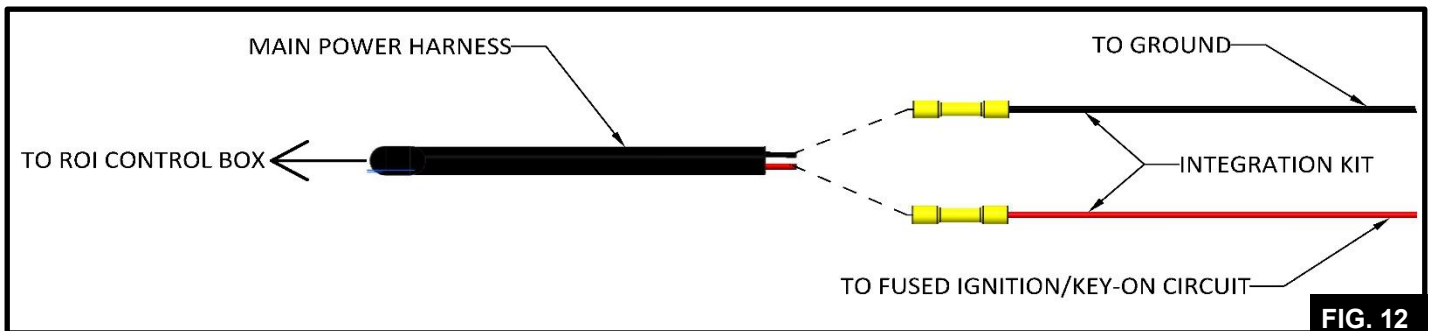

8. INSTALL NEW CAB SUSPENSION ELECTRICAL AND AIRLINE COMPONENTS (CONT.)

8.4

Option 1 RP1226 Connector

Verify the vehicle key is in the off position. Verify location of OE RP1226 connectors prior to continuing the installation. The RP1226 connector is a standardized electrical interface optionally provided by vehicle manufacturers to facilitate connection of the vehicle J1939 CAN bus to aftermarket vehicle accessories such as Electronic Logging Devices. The OEM may provide multiple RP1226 connectors to support additional accessory devices. Connecting multiple devices to the CAN signals of an RP1226 connector using Y-adaptors or splices is a violation of the TMC RP1226 and SAE J1939 standards because doing so could cause signal interference (**FIG. 14**). Tie in the RP1226 connector to the mating tie-in location on the vehicle and crimp the ignition and ground wires to the power harness. If the RP1226 connector is not available, proceed to step 8.5. Ensure the overall circuit rating is appropriate and fused to handle all loads. Fuse each branch independently, using the 10-amp fuse provided, and proceed to step 9.

8.5

Option 2 F32-D Connector

If there are no available RP1226 connector, use the secondary option F32-D connector. Crimp the power harness wires to the mating color wire in the F32-D Connector Kit. Insert the red wire into the tie in location in an available ignition/key-on circuit and fuse at 10 amps using the fuse provided. If there are no open circuits, an existing circuit may need to be spliced. Be sure the overall circuit rating is appropriate and fused to handle both loads. Fuse each branch independently, using the 10-amp fuse provided and an inline fuse holder (not provided) for the ROI Cabmate branch. Fuse the other branch per the equipment manufacturer's instructions. Fuse each branch independently, using the 10-amp fuse provided, and proceed to step 9.

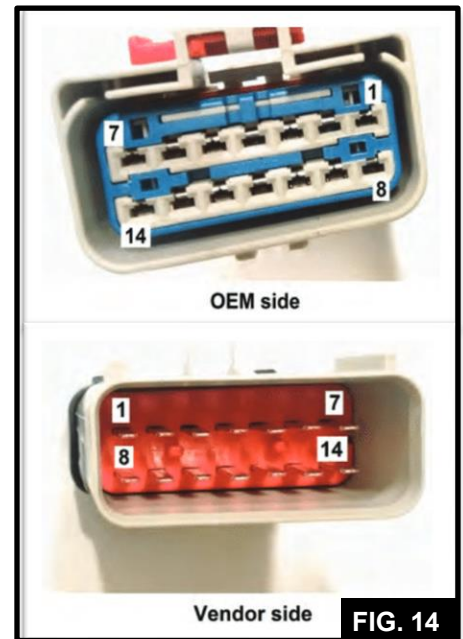

NOTICE

The information provided here is for reference only and was populated based on successful installations of the ROI Cabmate. An appropriate tie-in location on your vehicle will need to be determined, which may be different than what is provided here. Link Manufacturing does not accept responsibility for failures caused due to inappropriate connection to vehicle electrical circuits.

Possible Vehicle Connection locations for select Volvo models are as follows:

Ignition Tie-in: Option 1: RP1226 Connector
Option 2: F32-D connector beneath fuse panel.

Ground Tie-in: Option 1: RP1226 Connector
Option 2: F32-D connector beneath fuse panel.

9. VERIFICATION OF INSTALLATION

9.1

Verify the position sensor arm is above horizontal, indicating that the suspension is above design height. At design height the sensor arm should be horizontal and perpendicular to the linkage. You may need to lower the jack(s) supporting the cab to achieve this (**FIG.15**).

9.2

With no air in the suspension, verify a minimum of 0.75 inches of clearance between the frame-mounted components and the sleeper-mounted components.

9.3

Turn on the vehicle and allow the air tanks to fill. The cab air springs should now fill to design height.

9.4

Measure the air spring height as shown in (**FIG.1**) and verify it measures the same as recorded in step 5.1. If the design height is not correct, shut the vehicle off, adjust the linkage length accordingly, then restart the vehicle and repeat this step.

9.5

Verify the LED on the controller is flashing steadily, which indicates no faults. If the LED is not flashing steadily, see the Owner's Manual for troubleshooting information (**FIG.16**).

9.6

Check airline connections for air leaks and ensure all wire harnesses and airline is routed and secured appropriately.

9.7

Your ROI Cabmate installation is now complete. We hope you enjoy the ride. Please visit www.ROICabmate.com for more information or contact us at info@linkmfg.com if there is anything we can help you with.

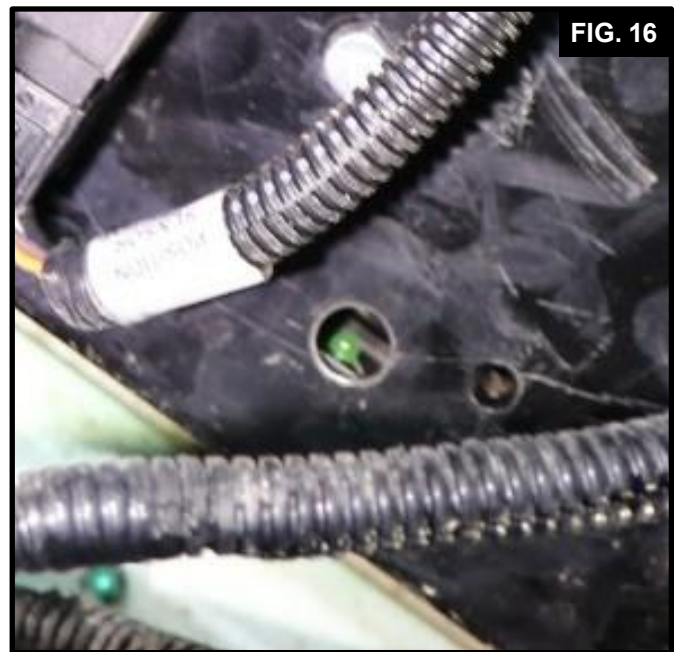
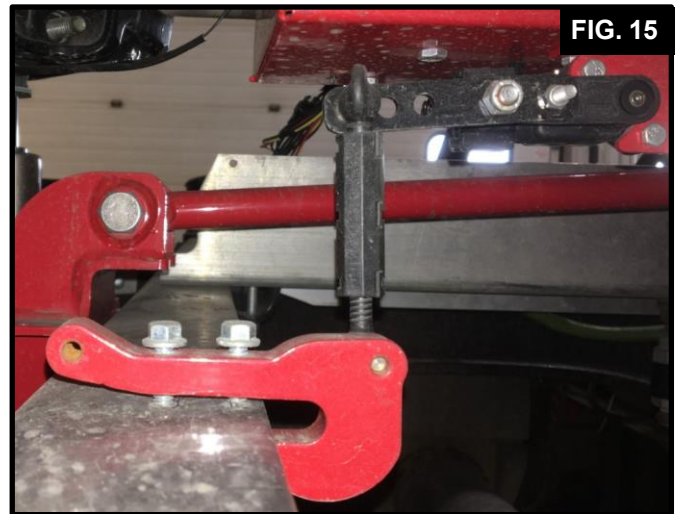

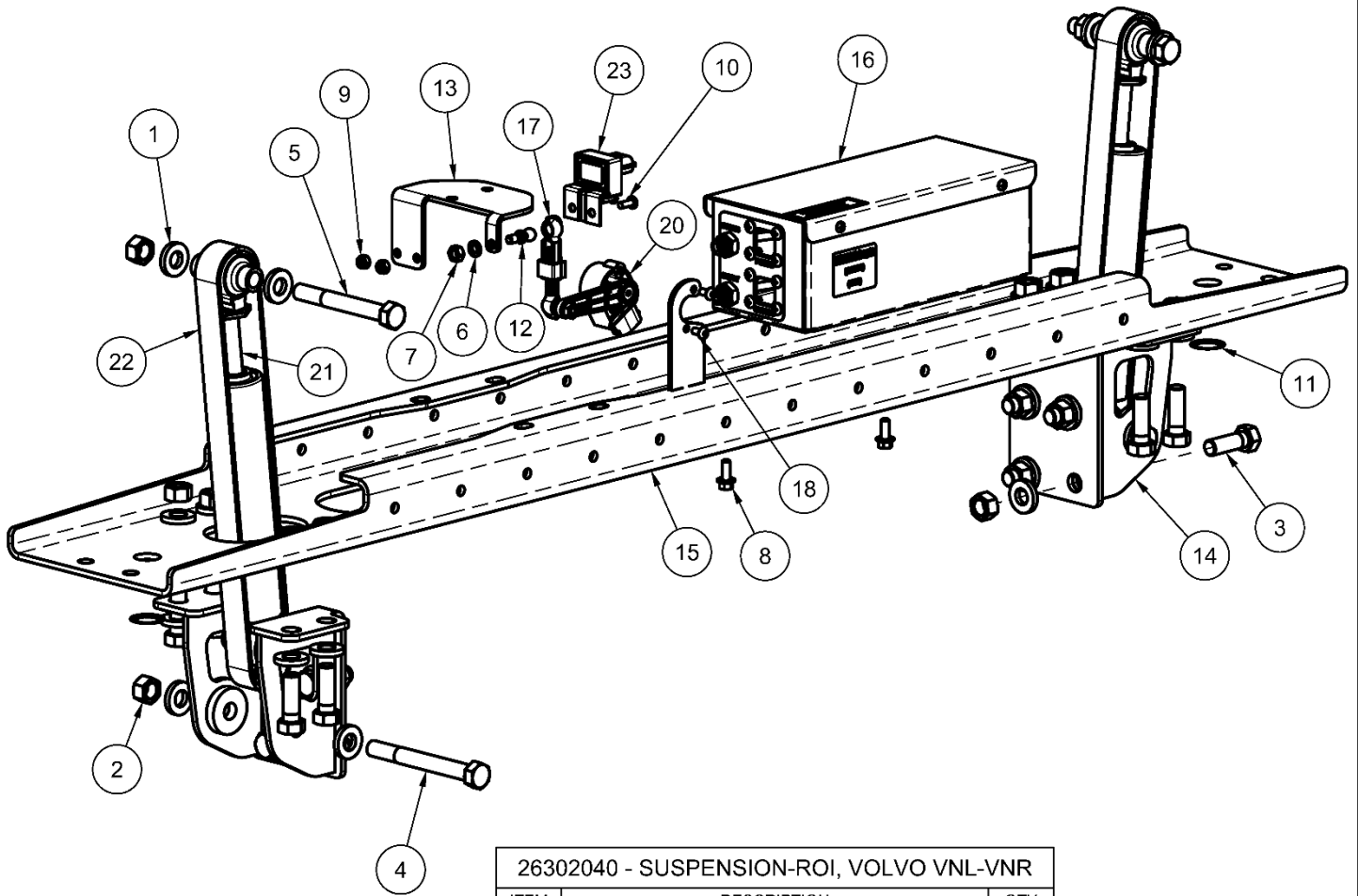

26302040 - SUSPENSION-ROI, VOLVO VNL-VNR

ITEM	DESCRIPTION	QTY
1	1/2 HARDENED WASHER, ZINC PLATED	40
2	1/2 UNC HEX TOP LOCK NUT (GR C)	20
3	1/2 X 1 1/2 UNC HEX CAP SCR (GR 5)	16
4	1/2 X 4 1/2 UNC HEX CAP SCR (GR 5)	2
5	1/2 X 4 UNC HEX CAP SCR (GR 5)	2
6	1/4 LOCK WASHER	2
7	1/4 UNC HEX NUT	2
8	1/4 X 5/8 FLANGE HEAD BOLT	2
9	10-24 NYLOCK NUT, SS	2
10	10-24 x 1/2 UNC CR PH MACH SCREW, SS	2
11	3/4 RETAINER RING	2
12	BALL-PIVOT, THREADED	2
13	BRACKET-MOUNT, ACCELEROMETER	1
14	BRACKET-MOUNT, FRAME	2
15	CHANNEL-CROSSMEMBER, LCR-AIRSPRING	1
16	ECU BOX ASSEMBLY	1
*	- HARNESS - PIGTAIL CONNECTOR, RP1226	1
*	- HARNESS-WIRE, POWER	1
*	- HARNESS-WIRE, SHOCK	1
17	LINKAGE-VALVE	1
18	M5X0.8X10 SOCKET BUTTON HD SS CAP SCREW	2
19	MANUAL-OWNERS-VOLVO	1
*	- ROI INSTALLATION ACCESSORIES, VOLVO	1
20	SENSOR-POSITION	1
21	SHOCK ABSORBER	2
22	STRAP-RETENTION	2
*	- VOLVO VN INSTALLATION INSTRUCTIONS	1
23	ZF ACCELEROMETER ASSEMBLY	1

*NOT PICTURED

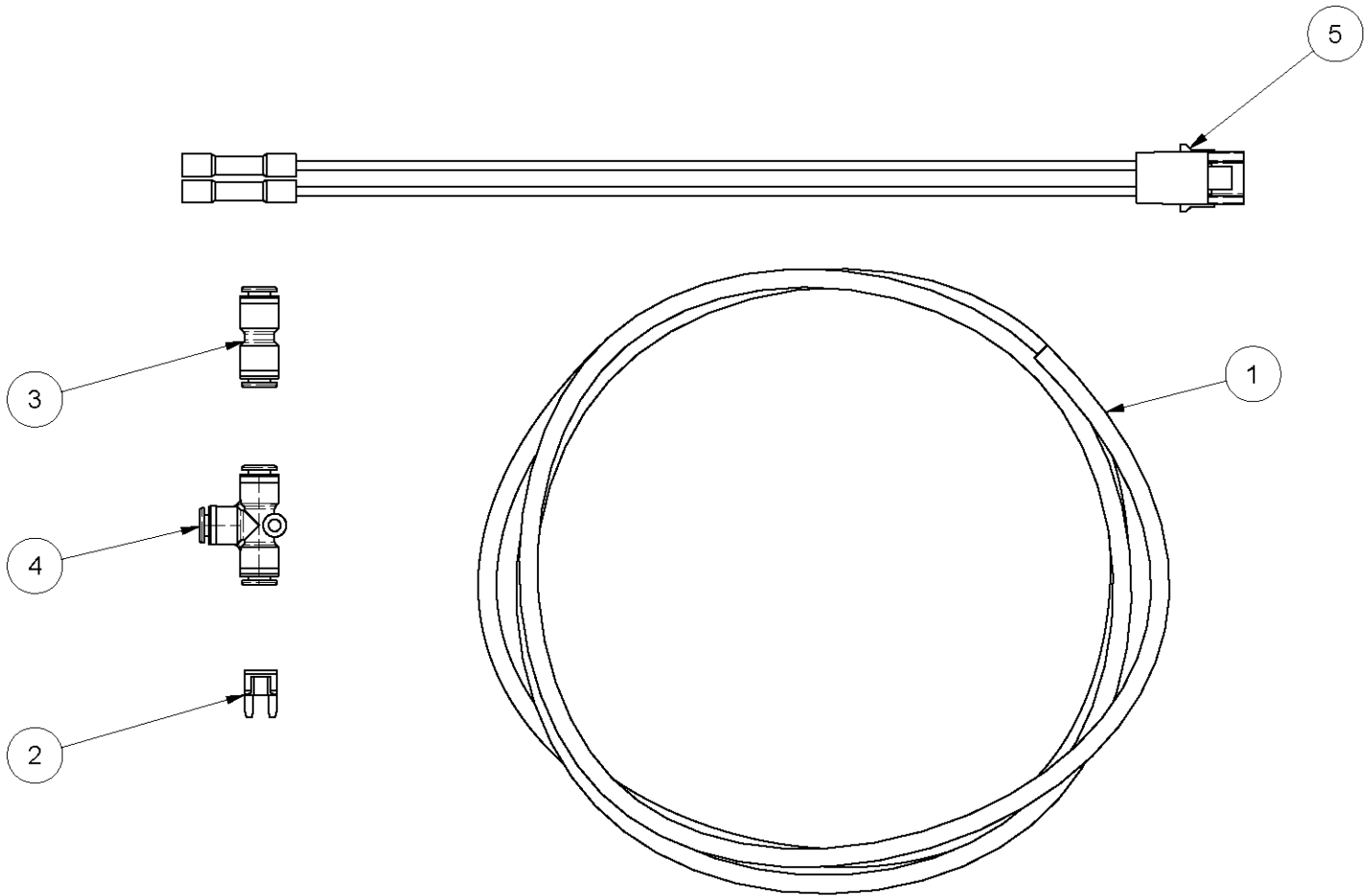

26303004 - ROI INSTALLATION ACCESSORIES, VOLVO		
ITEM	DESCRIPTION	QTY
1	AIRLINE-NYLON, .250 O.D., BULK (FEET)	10
2	FUSE-MINI AUTOMOTIVE, 10 AMP	1
3	UNION H, 1/4 TB	1
4	UNION TEE, 1/4 TB	1
5	WIRE-HARNESS, VOLVO	1

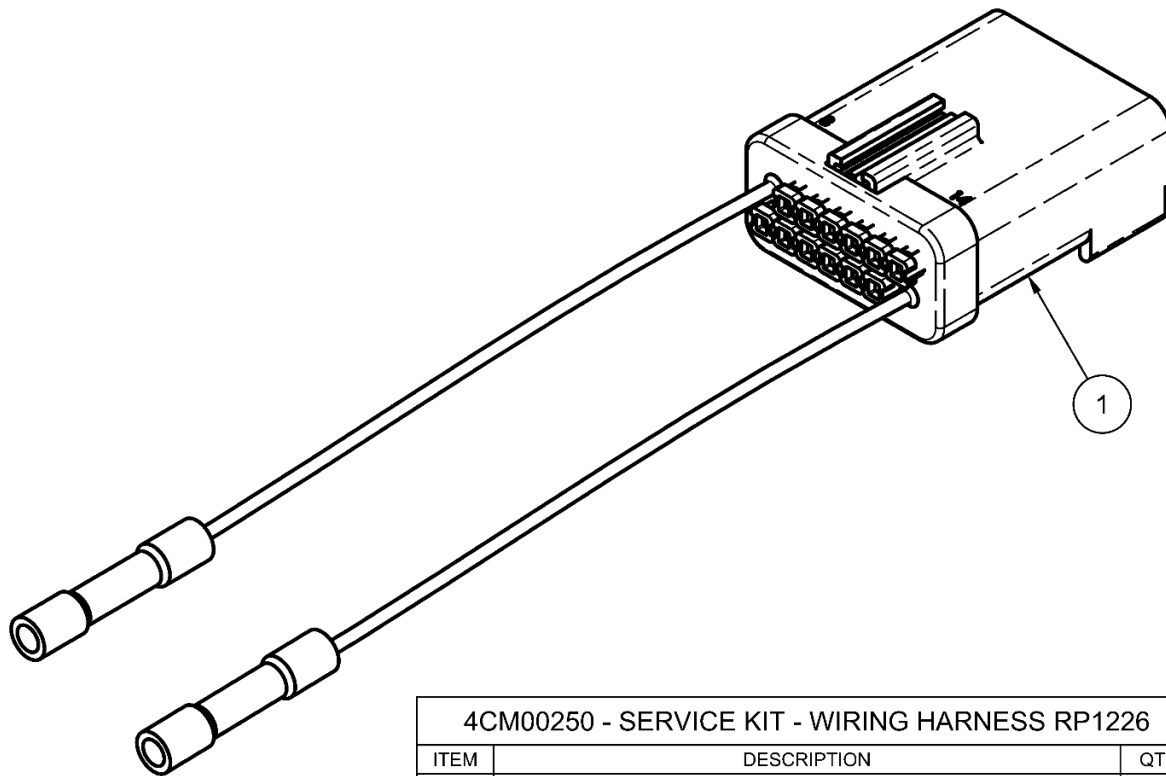

4CM00250 - SERVICE KIT - WIRING HARNESS RP1226		
ITEM	DESCRIPTION	QTY
1	HARNESS - PIGTAIL CONNECTOR, RP1226	1



LINK MANUFACTURING, LTD.
 223 15TH ST. NE, SIOUX CENTER, IA 51250
 1-800-222-6283 www.linkmfg.com